

In dynamic mode, long press PUSH to adjust speed, long press it again to adjust the speed in reverse. Short press PUSH, the two lamps will be turned on or off at the same time. To adjust the brightness, the user need to turn off the lamps first, and then long press it, the brightness will gradually increases from the lowest, dimming range is 1%-100%, release the PUSH within 5 seconds and then long press it to adjust the brightness in reverse. The speed divides into 10 levels. When the speed changes, the lamps will flash. It means the speed has been changed. The speed from 0 to 9 are as below:
0=0.5s; 1=1s; 2=2s; 3=3s; 4=5s; 5=10s; 6=15s; 7=30s; 8=60s; 9=120s

(2) Dynamic adjustment:

Double press PUSH to switch dimming curves.

Long press PUSH, the color temperature and brightness will be adjusted according to the curves below, then long press it to adjust in reverse. Short press PUSH, to turn ON or OFF the two lamps, no need to adjust the brightness again.

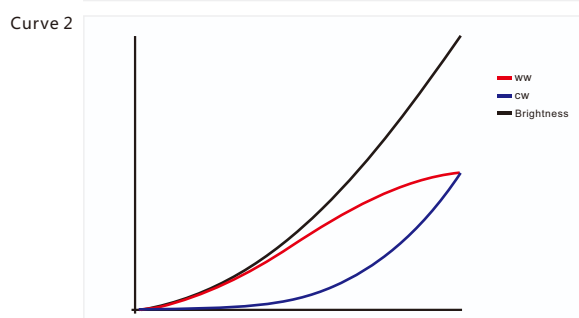
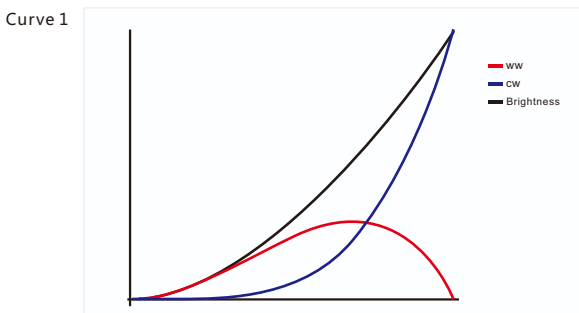

Constant Voltage CCT Controller User Manual



(Please read through this manual carefully before use)

1. Brief Introduction

Welcome to use this constant voltage CCT controller, it adopts PWM (Pulse-Width Modulation) digital brightness control technology; it changes the dimming modes by DIP switch and duplex push dim button, it's suitable for 2 channels' constant voltage CCT LED lights.

2. Specifications

MODEL	CCT Controller
Input voltage	DC12V-24V
Max output current	8A×2CH
Max output power	96W×2CH(12V) / 192W×2CH (24V)
Grey scale	4096Levels×2
Working temperature	-25-55°C
Product size	L176×W46×H30(mm)
Weight	145g

3. Basic Features

1. Automatically adapts to DC12V-24V.
2. 2 output channels, each channel 4096 grey scale, Lamp light soft and stable, without flicker
3. One PUSH or two PUSHs selectable, Static mode and dynamic mode switchable.
4. Power loss memory function.
5. Over current protection, short circuit protection.

4. Safety warnings

- Please don't install this controller in lightning, intense magnetic and high-voltage fields.
1. To reduce the risk of component damage and fire caused by short circuit, make sure correct connection
 2. Always be sure to mount this unit in an area that will allow proper ventilation to ensure a fitting temperature.
 3. Check if the voltage and power adapter suit the controller (please select DC12-24V power supply with constant voltage)
 4. Don't connect cables with power on; make sure a correct connection and no short circuit checked with instrument before power on.
 5. Please don't open controller cover and operate if problems occur. The manual is only suitable for this model; any update is subject to change without prior notice.

5. Dimensions

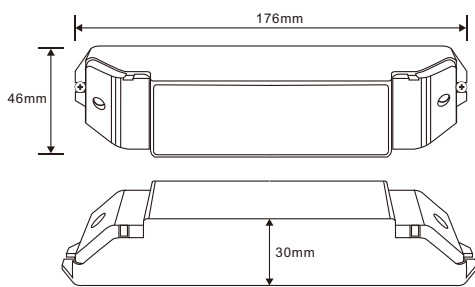

6. Operation instructions:

Operation instructions of two DIP switch :

	DIP1	Instruction	DIP2	Instruction
ON	TWO PUSH	Two PUSHs operation	STATIC	Static transfer
OFF	ONE PUSH	One PUSHs operation	DYNAMIC	Dynamic transfer

NOTE: The Static or Dynamic transfer function of DIP2 only suitable for one PUSH operation mode, not for two PUSH operation mode.

Detail operation instruction :

1. Two PUSHs : Conjunction Diagram and DIP setting

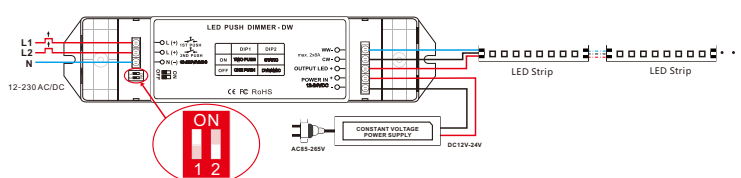

The first PUSH corresponds to WW channel, the second PUSH corresponds to CW channel. Double press any PUSH, to switch static mode and dynamic mode, Dynamic mode : WW->CW->WW Cycling. In static mode, short press PUSH, to turn on/off respective lights; Long press PUSH, to dim the respective lights, dimming range is 1%-100%. In dynamic mode, short press any of PUSHs, to turn on/off the lights at the same time, long press the first PUSH to adjust speed, long press the second PUSH to adjust the overall brightness, dimming range 1%-100%, long press it again to dim in reverse.

2. One PUSH (Either PUSH can be used) Conjunction Diagram and DIP setting

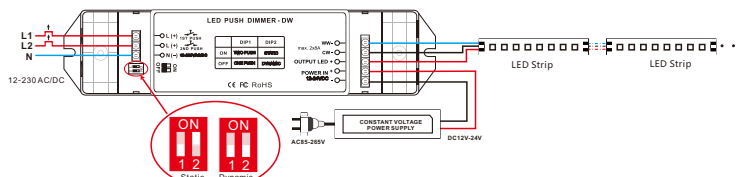

It divides into static adjustment and dynamic adjustment, and switch them by the second DIP switch

- (1) Static adjustment:

It has Static mode and dynamic mode, double press PUSH to switch static or dynamic mode.

In static mode, long press PUSH to change color temperature, stop to save the current color temperature. Press it again, the changing goes opposite. Short press PUSH, the two lamps will be turned on/off at the same time.

When adjust the brightness, the user needs to turn off two lamps, then long press it, the brightness will gradually increases from the lowest, dimming range is 1%-100%, release the PUSH within 5 seconds and then long press it to adjust the brightness in reverse.

The conjunction diagram of color temperature controller and power repeater : (If power is enough, the controller and the repeater can share the same power supply)

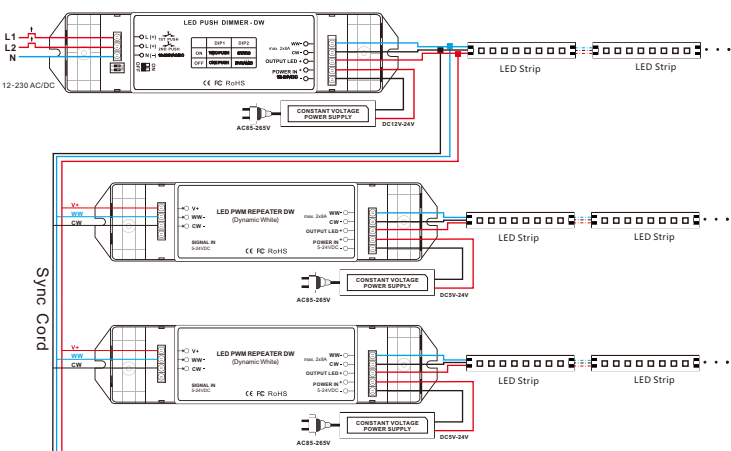

8. After-Sales

From the day you purchase our products within 3 years, if being used properly in accordance with the instruction, and quality problems occur, we provide free repair or replacement services except the following cases:

1. Any defects caused by wrong operations.
2. Any damages caused by inappropriate power supply or abnormal voltage.
3. Any damages caused by unauthorized removal, maintenance, modifying circuit, incorrect connections and replacing chips.
4. Any damages due to transportation, breaking, flooded water after the purchase.
5. Any damages caused by earthquake, fire, flood, lightning strike etc force majeure of natural disasters.
6. Any damages caused by negligence, inappropriate storing at high temperature and humidity environment or near harmful chemicals.
7. Product has been updated.